

Operating Instructions

Read and observe these Operating Instructions!

Self Drying Pumps

N 820.3 FT.40.18
N 840.3 FT.40.18

N 842.3 FT.40.18
N 860.3 FT.40.18



KNF Neuberger GmbH
Alter Weg 3
79112 Freiburg
Germany
Phone +49-(0)7664 / 5909-0
Fax +49-(0)7664 / 5909-99
E-Mail: info@knf.de
www.knf.de

Contents	Page
1. About this document	3
2. Use	4
3. Safety	5
4. Technical Data	7
5. Design and Function	12
6. Installation and connection.....	15
7. Operation.....	16
8. Servicing.....	21
9. Troubleshooting.....	29
10. Spare parts.....	31
11. Returns.....	31
12. Health and safety clearance and decontamination form.....	33

1. About this document

1.1. Using the Operating Instructions

The Operating Instructions are part of the pump.

- Carefully study the Operating Instructions before using a pump.
- Always keep the Operating Instructions handy in the work area.
- Pass on the Operating Instructions to the next owner.

Project pumps

Customer-specific project pumps (pump models which begin with "PJ" or "PM") may differ from the Operating Instructions.

- For project pumps, also observe the agreed upon specifications.

1.2. Symbols and Markings

Warning



WARNING

A danger warning is located here.

Possible consequences of a failure to observe the warning are specified here. The signal word, e.g. Warning, indicates the danger level.

- Measures for avoiding the danger and its consequences are specified here.

Danger levels

Signal word	Meaning	Consequences if not observed
DANGER	warns of immediate danger	Death or serious injuries and/or serious damage are the consequence.
WARNING	warns of possible danger	Death or serious injuries and/or serious damage are possible.
CAUTION	warns of a possibly dangerous situation	Minor injuries or damage are possible.

Tab. 1

Other information and symbols

- An activity to be carried out (a step) is specified here.
- 1. The first step of an activity to be carried out is specified here. Additional, consecutively numbered steps follow.

i This symbol refers to important information.

2. Use

2.1. Proper use

The pumps are exclusively intended for transferring gases and vapors.

Owner's responsibility

Operating parameters and conditions	<p>Only install and operate the pumps under the operating parameters and conditions described in chapter 4, Technical data.</p> <p>Make sure that the installation location is dry and the pump is protected against rain, splash, hose and drip water.</p>
Requirements for transferred medium	<p>Before using a medium, check whether the medium can be transferred danger-free in the specific application case.</p> <p>Before using a medium, check the compatibility of the materials of the pump head, diaphragm and valves with the medium.</p> <p>Only transfer gases which remain stable under the pressures and temperatures occurring in the pump.</p>
Drying systems	<p>Ensure that the entry of air into the pump during venting (drying system) could not result in the creation of reactive, explosive or otherwise hazardous mixtures (e.g. with the medium).</p>
Accessories	<p>Laboratory equipment or additional components connected to a pump have to be suitable for use with the pneumatic capabilities of the pump.</p>

2.2. Improper use

The pumps and the drying system may not be operated in an explosive atmosphere.

The pumps are not suitable for transferring dusts.

The pumps are not suitable for transferring liquids.

The pumps must not be used to create vacuum and overpressure simultaneously.

An overpressure must not be applied to the suction side of the pump.

3. Safety

i Note the safety precautions in chapters 6. *Installation and connection*, and 7. *Operation*.

The pumps are built according to the generally recognized rules of technology and in accordance with the occupational safety and accident prevention regulations. Nevertheless, dangers can result during their use which lead to injuries to the user or others, or to damage to the pump or other property.

Only use the pumps when they are in a good technical and proper working order, in accordance with their intended use, observing the safety advice within the operating instructions, at all times.

Personnel

Make sure that only trained and instructed personnel or specially trained personnel work on the pumps. This especially applies to assembly, connection and servicing work.

Make sure that the personnel has read and understood the operating instructions, and in particular the "Safety" chapter.

Working in a safety-conscious manner

Observe the accident prevention and safety regulations when performing any work on the pump and during operation.

Do not expose any part of your body to the vacuum.

Open housing parts with notice sticker (see fig. 1) only after separating mains plug from power source.

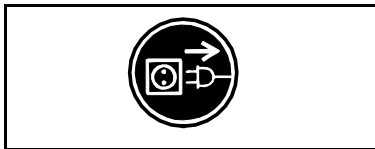

Fig. 1: Notice sticker

Handling dangerous media

When transferring dangerous media, observe the safety regulations when handling these media.

Handling flammable media

Be aware that the pumps are not designed to be explosion-proof.

Make sure the temperature of the medium is always sufficiently below the ignition temperature of the medium, to avoid ignition or explosion. This also applies for unusual operational situations.

Note that the temperature of the medium increases when the pump compresses the medium.

Hence, make sure the temperature of the medium is sufficiently below the ignition temperature of the medium, even when it is compressed to the maximum permissible operating pressure of the pump. The maximum permissible operating pressure of the pump is stated in the technical specifications (see chapter 4).

If necessary, consider any external sources of energy, such as radiation, that may add heat to the medium.

In case of doubt, consult the KNF customer service.

Environmental protection

Store all replacement parts in a protected manner and dispose of them properly in accordance with the applicable environmental protection regulations. Observe the respective national and international regulations. This especially applies to parts contaminated with toxic substances.

Standards	<p>The pumps conform to the Directive 2011/65/EU (RoHS2).</p> <p>The pumps conform to the safety regulations of the Directive 2014/30/EU concerning Electromagnetic Compatibility and the Directive 2006/42/EC concerning Machinery.</p> <p>The following harmonized standards have been used:</p> <ul style="list-style-type: none">▪ DIN EN 61010-1▪ DIN EN 61326-1 - class A▪ DIN EN 50581 <p>The pumps correspond to IEC 664:</p> <ul style="list-style-type: none">▪ the overvoltage category II▪ the pollution degree 2.
Customer service and repairs	<p>Only have repairs to the pump carried out by the KNF Customer Service responsible.</p> <p>Only authorized personnel should open those parts of the housing that contain live electrical parts.</p> <p>Use only genuine parts from KNF for servicing work.</p>

4. Technical Data

i All pumps are secured against overheating with a thermal switch and are equipped with a mains fuse.

Pump materials

<i>Component</i>	<i>Pump material</i>
Pump head	PTFE
Diaphragm	PTFE coated
Valve	FFPM

Tab. 2

i Refer to the type plate for the pump's electrical configuration.

N 820.3 FT.40.18

<i>Pneumatic performance</i>			
Max. permissible operating pressure [bar g]	1.0		
Ultimate vacuum [mbar abs.]	10		
Delivery rate at atm. pressure [l/min]*	20		
<i>Pneumatic connections</i>			
Hose connection [mm]	ID 10		
<i>Ambient and media temperature</i>			
Permissible ambient temperature	+ 5 °C to + 40 °C		
Permissible media temperature	+ 5 °C to + 40 °C		
<i>Other parameters</i>			
Weight [kg]	9.6		
Dimensions : L x H x W [mm]	312 x 220 x 177		
Maximum permissible ambient relative humidity	80 % for temperatures up to 31 °C, decreasing linearly to 50 % at 40 °C		
Max. altitude of site [m above sea level]	2000		
<i>Electrical Data</i>			
Voltage [V]	100	115	230
Frequency [Hz]	50/60	60	50
Max. operating current [A]	1.8	1.2	0.7
Power consumption pump [W]	130	130	120
Maximum permitted mains voltage fluctuations	+/- 10 %	+/- 10 %	+/- 10 %
Fuse pump (2x) T [A]	3.15	2.5	1.6
Protection class motor	IP44		

Tab. 3

* Liters in standard state (1,013 mbar)

N 840.3 FT.40.18

<i>Pneumatic performance</i>			
Max. permissible operating pressure [bar g]	1.0		
Ultimate vacuum [mbar abs.]	10		
Delivery rate at atm. pressure [l/min]*	34		
<i>Pneumatic connections</i>			
Hose connection [mm]	ID 10		
<i>Ambient and media temperature</i>			
Permissible ambient temperature	+ 5 °C to + 40 °C		
Permissible media temperature	+ 5 °C to + 40 °C		
<i>Other parameters</i>			
Weight [kg]	12.9		
Dimensions : L x H x W [mm]	341 x 239 x 189		
Maximum permissible ambient relative humidity	80 % for temperatures up to 31 °C, decreasing linearly to 50 % at 40 °C		
Max. altitude of site [m above sea level]	2000		
<i>Electrical Data</i>			
Voltage [V]	100	115	230
Frequency [Hz]	50/60	60	50
Max. operating current [A]	4.4	3.2	1.5
Power consumption pump [W]	220	250	245
Maximum permitted mains voltage fluctuations	+/- 10 %	+/- 10 %	+/- 10 %
Fuse pump (2x) T [A]	6.3	6.3	3.15
Protection class motor	IP44		

Tab. 4

* Liters in standard state (1,013 mbar)

N 842.3 FT.40.18

<i>Pneumatic performance</i>			
Max. permissible operating pressure [bar g]	1.0		
Ultimate vacuum [mbar abs.]	4		
Delivery rate at atm. pressure [l/min]*	34		
<i>Pneumatic connections</i>			
Hose connection [mm]	ID 10		
<i>Ambient and media temperature</i>			
Permissible ambient temperature	+ 5 °C to + 40 °C		
Permissible media temperature	+ 5 °C to + 40 °C		
<i>Other parameters</i>			
Weight [kg]	13.7		
Dimensions : L x H x W [mm]	341 x 242 x 189		
Maximum permissible ambient relative humidity	80 % for temperatures up to 31 °C, decreasing linearly to 50 % at 40 °C		
Max. altitude of site [m above sea level]	2000		
<i>Ambient and media temperature</i>			
Permissible ambient temperature	+ 5 °C to + 40 °C		
Permissible media temperature	+ 5 °C to + 40 °C		
<i>Electrical Data</i>			
Voltage [V]	100	115	230
Frequency [Hz]	50/60	60	50
Max. operating current [A]	4.4	3.2	1.5
Power consumption pump [W]	260	290	245
Maximum permitted mains voltage fluctuations	+/- 10 %	+/- 10 %	+/- 10 %
Fuse pump (2x) T [A]	6.3	6.3	3.15
Protection class motor	IP44		

Tab. 5

* Liters in standard state (1,013 mbar)

N 860.3 FT.40.18

<i>Pneumatic performance</i>			
Max. permissible operating pressure [bar g]	1.0		
Ultimate vacuum [mbar abs.]	4		
Delivery rate at atm. pressure [l/min]*	60		
<i>Pneumatic connections</i>			
Hose connection [mm]	ID 12		
<i>Ambient and media temperature</i>			
Permissible ambient temperature	+ 5 °C to + 40 °C		
Permissible media temperature	+ 5 °C to + 40 °C		
<i>Other parameters</i>			
Weight [kg]	14.8		
Dimensions : L x H x W [mm]	331 x 278.5 x 291		
Maximum permissible ambient relative humidity	80 % for temperatures up to 31 °C, decreasing linearly to 50 % at 40 °C		
Max. altitude of site [m above sea level]	2000		
<i>Electrical Data</i>			
Voltage [V]	100	115	230
Frequency [Hz]	50/60	60	50
Max. operating current [A]	4.8	2.7	1.6
Power consumption pump [W]	260	240	220
Maximum permitted mains voltage fluctuations	+/- 10 %	+/- 10 %	+/- 10 %
Fuse pump (2x) T [A]	6.3	6.3	3.15
Protection class motor	IP54		

Tab. 6

* Liters in standard state (1,013 mbar)

5. Design and Function

Design N 820.3 FT.40.18 , N 840.3 FT.40.18 , N 842.3 FT.40.18

- 1 Connection piece
- 2 Pneumatic connection
- 3 Pump head
- 4 Outlet (pressure side)
- 5 Inlet (suction side)
- 6 Power switch pump
- 7 Venting valve
- 8 Power switch drying system
- 9 Control box

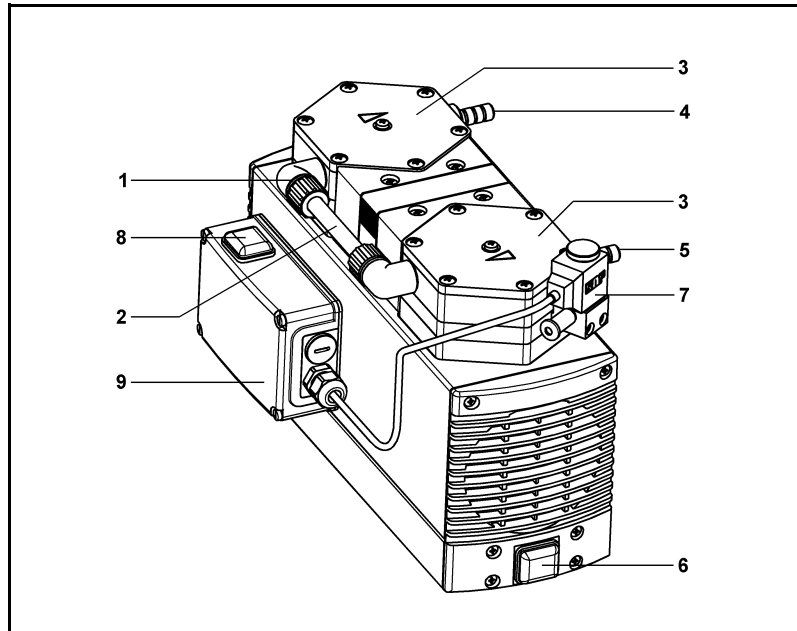

Fig. 2: Diaphragm pump (shown: pump N 840.3 FT.40.18, symbolic)

Design N 860.3 FT.40.18

- 1 Inlet (suction side)
- 2 Outlet (pressure side)
- 3 Pneumatic connection
- 4 Connection piece
- 5 Pump head
- 6 Power switch pump
- 7 Connecting box
- 8 Fan cover
- 9 Power switch drying system
- 10 Control box
- 11 Pump head
- 12 Venting valve

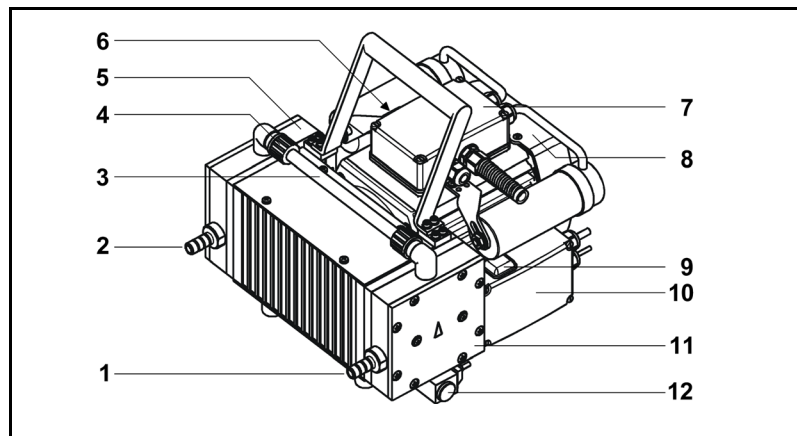

Fig. 3: Diaphragm pump N 860.3 FT.40.18

Function Diaphragm Pump

- 1 Outlet valve
- 2 Inlet valve
- 3 Transfer chamber
- 4 Diaphragm
- 5 Eccentric
- 6 Connecting rod
- 7 Pump drive

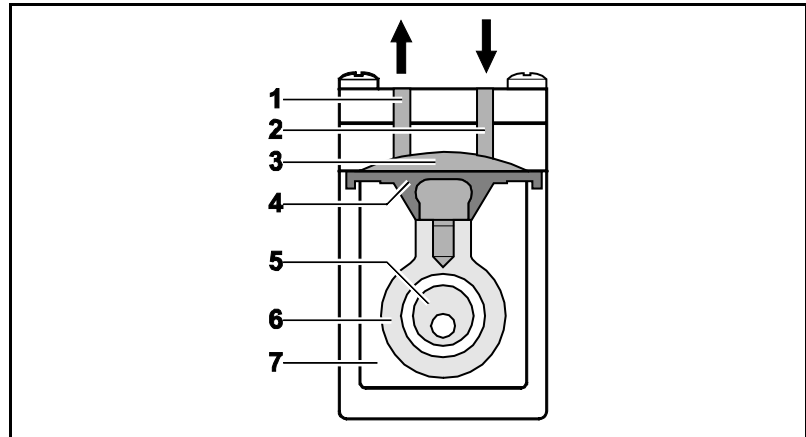

Fig. 4: Pump head

Diaphragm pumps transfer, compress (depending on pump version) and evacuate gases and vapors.

The elastic diaphragm (4) is moved up and down by the eccentric (5) and the connecting rod (6). In the downward stroke it aspirates the gas to be transferred via the inlet valve (2). In the upward stroke, the diaphragm presses the medium out of the pump head via the outlet valve (1). The transfer chamber (3) is hermetically separated from the pump drive (7) by the diaphragm.

Description, Operating Conditions

Where gases of high humidity have to be evacuated condensation may collect in the pump head; as a result, the effectiveness of the pump decreases.

Thanks to the drying system it is possible during evacuation to blow the condensed liquid out of the pump heads at high speed, while maintaining the vacuum in the recipient at a constant level. After drying the pump heads the pumps achieve a greatly improved vacuum and evacuate much faster than pumps without a drying system.

The drying system utilizes the pressure difference between the transfer chamber (fig. 4/3) and the surrounding atmosphere.

The venting valve (fig. 2/7 or fig. 3/12) at suction side pump head is opened by the control system, permitting air to enter the evacuated pump head. As a result of the increase in pressure in the pump head, the inlet valve of the first pump head closes by itself, thereby sealing off the connection to the source being evacuated.

By contrast, the outlet valve and both valves of the second pump head now open automatically; the condensation is expelled from the pump head at high speed.

Pumps can operate with or without the drying system. The drying system is activated by a switch on the control box. If the drying system remains switched off the pumps operate in the conventional way.

The control for the drying system is effected via three variables:

- The time between switching on the drying system and the first ventilation of the pump heads (t_1)
- The duration of the ventilation of the pump heads (t_2)
- The interval between pump head ventilation operations (t_3).

For t_1 to t_3 standard values are set in the factory.

- $t_1 = 210$ sec
- $t_2 = 2.0$ sec
- $t_3 = 40$ sec

In addition to this, the drying process can also be individually adapted to a process sequence. To do this, the values for t_1 , t_2 , and t_3 can be altered (see chapter 7.4). The pump must be disconnected from the electricity mains beforehand.

6. Installation and connection

Only install the pumps under the operating parameters and conditions described in chapter 4, Technical data.

Observe the safety precautions (see chapter 3).

6.1. Installation

- Before installation, store the pump at the installation location to bring it up to room temperature.
- Dimensions → See chapter 4, Technical data, for the dimensions of pump.
- Cooling air supply → Install the pump so that the motor fan can intake sufficient cooling air.
- Installation location → Make sure that the installation location is dry and the pump is protected against rain, splash, hose and drip water.
- Choose a safe location (flat surface) for the pump.
- Protect the pump from dust.
- Protect the pump from vibration and jolt.

6.2. Connection

- Connected components → Only connect components to the pump which are designed for the pneumatic data of the pump (see chapter 4).
- Pump exhaust → If the pump is used as a vacuum pump, safely discharge the pump exhaust at the pump's pneumatic outlet.
- Connection **i** A marking on the pump head shows the direction of flow.
 1. Remove the protective plugs from the pneumatic connectors of the pump.
 2. Connect the suction line and pressure line.
 3. Lay the suction and pressure line at a downward angle to prevent condensate from running into the pump.
 4. At the end of the pressure line, install a container for collecting the condensation that is drained from the pump.
 5. Insert the power cable's plug into a properly installed shockproof socket.

7. Operation

7.1. Preparing for Start-up

Before switching on the pump, observe the following points:

	Operational requirements
Pump	<ul style="list-style-type: none"> ▪ All hoses attached properly ▪ Fan openings not blocked ▪ Specifications of the power supply correspond with the data on the pump's type plate. ▪ The pump outlet is not closed or constricted. ▪ Container at the end of pressure line.

Tab. 7

7.2. Starting

- Only operate the pump under the operating parameters and conditions described in chapter 4, Technical data.
- Make sure the pump is used properly (see chapter 2.1).
- Make sure the pump is not used improperly (see chapter 2.2).
- Observe the safety precautions (see chapter 3).



WARNING

Hazard of the pump head bursting due to excessive pressure increase

- Do not exceed max. permissible operating pressure (see chapter 4).
- Monitor pressure during operation.
- If the pressure exceeds the maximum permissible operating pressure, immediately shut down pump and eliminate fault (see chapter 9. Troubleshooting).
- Only throttle or regulate the air or gas quantity in the suction line to prevent the maximum permissible operating pressure from being exceeded.
- If the air or gas quantity in the pressure line is throttled or regulated, make sure that the maximum permissible operating pressure of the pump is not exceeded.

i Excessive pressure (with all of the related hazards) can be prevented by placing a bypass line with a pressure-relief valve between the pressure and suction side of the pump. For further information, contact your KNF technical adviser.

**WARNING**

Reactive mixtures can cause personal injury and pump damage.

During the drying process of pump heads these are vented by the vent valve.

→ Before starting a pump, if the air is supplied via the vent valve ensure that there is no risk of the formation of reactive, explosive or otherwise hazardous mixtures. (Use inert gas where appropriate).

Pump standstill

→ With the pump at a standstill, open pressure and suction lines to normal atmospheric pressure.

**WARNING**

Automatic starting can cause personal injury and pump damage

When the operation of the pump is interrupted by the thermal switch, the pump will restart automatically after cooling down.

→ After triggering of the thermal protection or in the event of power failure, remove the pump's mains plug from the socket so that the pump cannot start uncontrollably.

→ Attempt work on the pump only if the pump is separated from mains power.

7.3. Switching pump on and off

Switching pump on

i The pump may not start up against pressure during switch-on. This also applies in operation following a brief power failure. If a pump starts against pressure, it may block. This activates the thermal switch, and the pump switches off.

- Make sure that no pressure is present in the lines during switch-on.
- Switch on pump with mains switch (see fig. 2 or 3).
- If cyclic drying of the pump heads is required in the current evacuation process, switch the drying system on at the mains switch of the control box (see fig. 2 or 3).

i The drying system will only work with the pump switched on.

i The drying system should only be switched on if a container has been attached to the pressure line of the pump which will catch the condensate; otherwise the condensate will flow out uncontrolled.

i When the drying system is switched on, the time period t_1 (time until the first venting of the pumps heads) will begin. If it is intended that t_1 should run from the pump starting, the drying system should be switched on before the pump.

i For the variables t_1 to t_3 of the drying system, see chapter 7.4.

Switching off the pump/removing from operation

- Purge the pump including the connecting hoses with air (if necessary for safety reasons: with an inert gas) at full flow rate for about 5 minutes (see chapter 8.2.1).
- If the drying system is switched on: Switch the drying system off at the main switch of the control box (see fig. 2 or fig. 3).
- Switch off pump with mains switch (see fig. 2 or 3).
- Open pressure and suction lines to normal atmospheric pressure.
- Disconnect the power source.

7.4. Drying system: Changing settings

The variables of the drying system can be adapted to a process sequence.

Drying system control box

- t_1 : Time between switching on the drying system and the first ventilation of the pump heads.
- t_2 : Duration of the ventilation of the pump heads.
- t_3 : The interval between pump head ventilation operations.

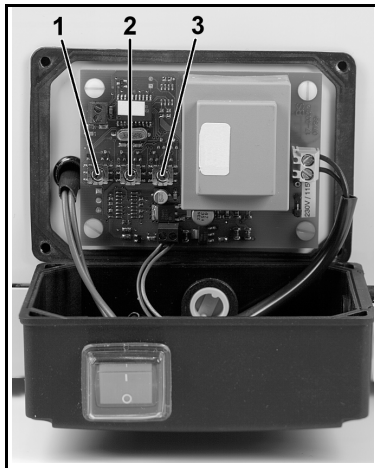

Fig. 5: Control box (opened) of drying system with switches 1, 2, 3

Switch setting	Switch 1 t_1 in sec	Switch 2 t_2 in sec	Switch 3 t_3 in sec
0	t_3	1.0	10.0
1	60.0	1.5	15.0
2	90.0	2.0	25.0
3	120.0	2.5	40.0
4	150.0	3.0	60.0
5	180.0	3.5	120.0
6	210.0	4.0	180.0
7	240.0	5.0	300.0
8	300.0	7.5	600.0
9	360.0	10.0	900.0

Tab. 8: Variables and values

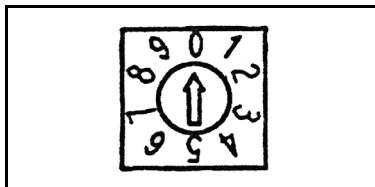

Fig. 6: Switch for setting the drying system

Switch	Switch setting	Time in sec
1	6	210.0
2	2	2.0
3	3	40.0

Tab. 9: Work setting

Changing settings



Extreme danger from electrical shock!

→ Disconnect the pump power supply before working on the pump.

DANGER

→ Make sure the pump is de-energized and secure.

1. Disconnect the pump from the mains by pulling the plug out of the socket.
2. Check that the pump and the drying system are dead and secure them.
3. At the control box, loosen the collar nut of the cable inlet. Use a slotted screwdriver to release the four screws, then fold the cover forwards and lay it down (see fig. 5).

i The control box may only be opened if there is no risk of moisture precipitating on the control unit.

4. Set the desired values at switches S1, S2, and S3 (see fig. 5). See Table 8 for an explanation of the switches and for the values which can be set.
5. Replace the cover on the control box. Take care to ensure that the seal is properly in place. Tighten the four screws of the cover to finger tightness. Then tighten the collar nut of the cable inlet.

8. Servicing

8.1. Servicing Schedule

Component	Servicing interval
Pump	Regular inspection for external damage or leaks
Diaphragm and valve plates/ sealings	Replace at the latest, when pump output decreases

Tab. 10

8.2. Cleaning

i When cleaning, make sure that no liquids enter the inside of the housing.

8.2.1. Flushing Pump

→ Before switching off the pump, flush it with air (if necessary for safety reasons: with an inert gas) for about five minutes under atmospheric conditions (ambient pressure).

8.2.2. Cleaning Pump

→ Only use solvents for cleaning if the head materials cannot be attacked (check the resistance of the material!).

→ If compressed air is available, blow out the components.

8.3. Changing Diaphragm and Valve Plates/Sealings

8.3.1. N 820.3 FT.40.18, N 840.3 FT.40.18, N 842.3 FT.40.18

- Conditions
- Pump is switched off and mains plug is removed from the socket
 - Pump is clean and free of hazardous materials
 - Tubes removed from pump's pneumatic inlet and outlet

Tools and material

Qty	Material
1	Service Set (see Chapter 10)
1	Phillips-head screwdriver No. 2
1	Felt-tip pen

Tab. 11

- Information on procedure
- ➔ Always replace diaphragm and valve plates/sealings together to maintain the pump performance.
- With multi-head pumps, parts of the individual pump heads can be confused.
- ➔ Replace the diaphragm and valve plates/sealings of the individual pump heads consecutively.



WARNING

Health hazard due to dangerous substances in the pump!

Depending on the substance transferred, caustic burns or poisoning are possible.

- ➔ Wear protective clothing if necessary, e.g. protective gloves.
- ➔ Flush pump before replacing the diaphragm and valve plates/sealings (see chapter 8.2.1).

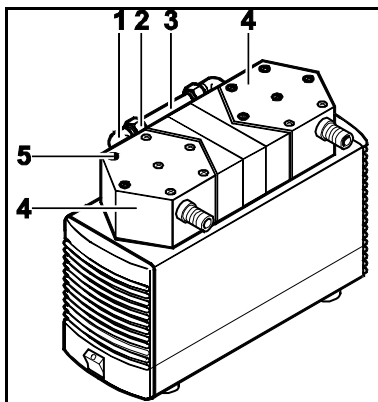

Fig. 7: Removing pump head

Removing pump head

i Pump N 842.3 FT.40.18 has a round shape of head, not a hexagonal.

1. On the pneumatic head connection (3), loosen the union nuts (2) by hand. Then slightly loosen the angle-fitting (1) in the pump head (4) by turning it anticlockwise, so that the connecting tube can be pulled out.
2. At both pump heads mark the position of top plate (fig. 10/5), head plate (fig. 10/6), intermediate plate (fig. 10/8) and adapter relatively to each other by a drawing line with a felt-tip pen. This helps to avoid incorrect assembly later.

i In version N 842.3 FT.40.18, twelve (instead of three) screws must be loosened in the next work step.

3. Loosen the outer screws (fig. 7/5) on the pump heads.
4. Carefully remove pump heads.

i The magnetic valve of the drying system remains fitted in this situation.

Change diaphragm

i Replace the diaphragms of both pump heads consecutively in order to ensure that the same number of diaphragm spacers is used as before.

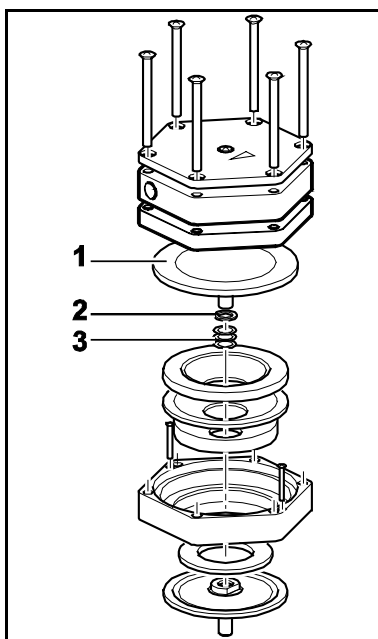

Fig. 8: Changing diaphragm

1. Push down one diaphragm until other diaphragm is pushed upwards to its highest position.
2. Carefully unscrew the upper diaphragm (1) anti-clockwise using both hands.
3. Replace spacer thick (2) and spacers thin (3) onto the screw thread of the new diaphragm (same number and order).
4. Screw in the new diaphragm and tighten it by hand.
5. Carry out steps 1 to 4 for the second pump head.

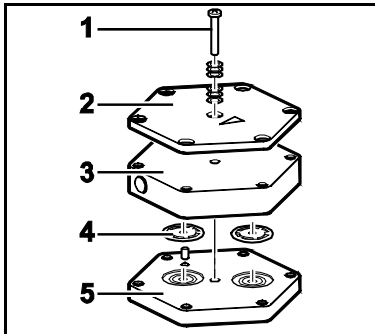

Fig. 9: Changing valve plates/sealings

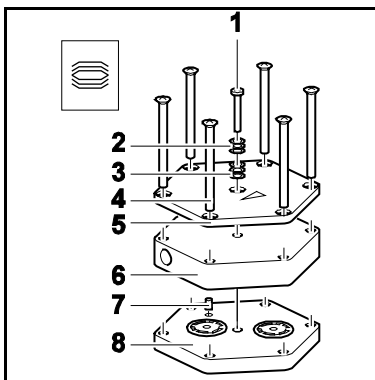

Fig. 10: Refitting pump head

Change valve plates/sealings

i Replacing the valve plates/sealings of both pump heads consecutively.

i In version N 842.3 FT.40.18, three (instead of one) screws must be loosened in the first work step.

1. At one pump head: Loosen screw(s) (1) in the center of the top plate (2).
2. Remove top plate (2) and head plate (3) from intermediate plate (5).
Valve plates/sealings (4) are visible.
3. Remove old valve plate/sealings.
4. Clean intermediate plate (5) carefully (if there should be deposits in the recesses in the intermediate plate).
5. Insert new valve plates/sealings (4) in the recesses in the intermediate plate (5).
6. Carry out steps 1 to 5 for the second pump head.
7. Dispose of the old diaphragms and valve plates/sealings properly.

Refitting pump head

1. At one pump head: Apply pressure all around the edge of the diaphragm.
2. Place the intermediate plate (8) with valve plates/sealings on the adapter in accordance with the felt-tip pen marking.
3. Place the head plate (6) on the intermediate plate (8) in the position indicated by the guide pin (7).
4. Place the top plate (5) on the head plate (6) in accordance with the felt-tip pen marking.

i In version N 842.3 FT.40.18, twelve (instead of three) screws must be tightened in the next work step.

5. Gently tighten screws (4) in diagonal order (tightening torque: N 820: 7 Nm; N 840/842: 8 Nm).

i In version N 842.3 FT.40.18, three (instead of one) screws must be tightened in the next work step.

6. Insert screw(s) (1) with disk springs (2, 3) in the center of the top plate (5). In doing so, make sure that the disk springs are arranged properly (see fig. 10).
7. Screw in the screw/screws (1) in the centre of the pump top plate (5) until it is flush with the top plate (they are flush with the top plate); then screw one final half turn to tighten (tightening torque: 25 Ncm).
8. Carry out steps 1 to 7 for the second pump head.
9. Refit the pneumatic head connection: Place tube onto the connecting part of the angle fitting, turn angle fitting to a

straight position and tighten the union nut.

Final steps

1. Reconnect suction and pressure line to the pump.
2. Reconnect the pump to the electricity supply.

If you have any questions about servicing call your KNF technical adviser (see last page for contact telephone number).

8.3.2. N 860.3 FT.40.18

- Conditions
- Pump is switched off and mains plug is removed from the socket
 - Pump is clean and free of hazardous materials
 - Tubes removed from pump’s pneumatic inlet and outlet

Spare parts/tools

Spare part/tool
Service Set (according to chapter 10)
Philips screwdriver No. 2
Screwdriver, blade width 2 mm
Felt-tip pen

Tab. 12

Information on procedure

- ➔ Always replace diaphragm and valve plates/sealings together to maintain the pump performance.

With multi-head pumps, parts of the individual pump heads can be confused.

- ➔ Replace the diaphragm and valve plates/sealings of the individual pump heads consecutively.



WARNING

Health hazard due to dangerous substances in the pump!

Depending on the substance transferred, caustic burns or poisoning are possible.

- ➔ Wear protective clothing if necessary, e.g. protective gloves.
- ➔ Flush pump before replacing the diaphragm and valve plates/sealings (see chapter 8.2.1).

- 1 Valve plate/sealing
- 2 Top plate
- 3 Cross recessed raised cheese head screw
- 4 Disk spring
- 5 Housing
- 6 Diaphragm
- 7 Diaphragm spacer(s)
- 8 Connecting rod
- 9 Intermediate plate
- 10 Head plate
- 11 Cross recessed raised countersunk head screw

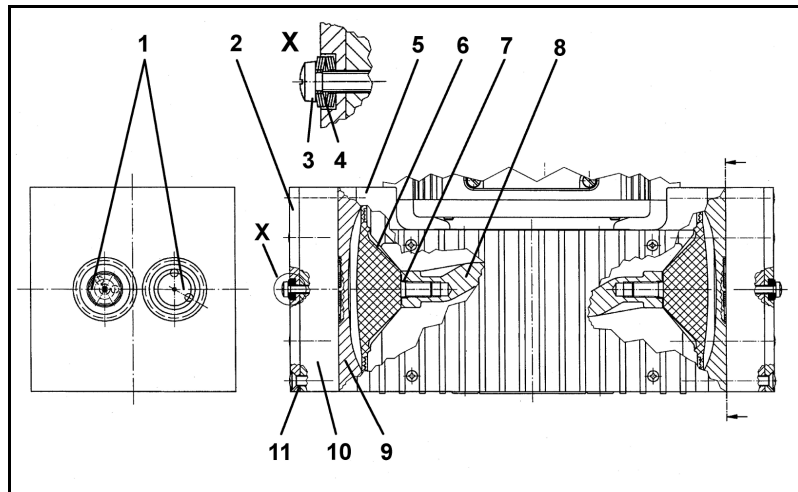

Fig. 11: Cross section of pump heads for pump N 860.3 FT.40.18 (symbolic)

Removing pump head

1. On the pneumatic head connections, loosen one of the union nuts by hand. Then slightly loosen the angle-fitting in the pump head by turning it anticlockwise, so that the connecting tube can be pulled out
2. Undo the screws that hold the fan cover (see fig. 3/8, page 12) and remove the fan cover from the motor.
3. At both pump heads make a mark (M) on the top plate (fig. 11/2), head plate (10), intermediate plate (9), and housing (5) with a felt-tip pen. This is to ensure that the parts will be reassembled correctly at a later stage.
4. Undo the eight screws (11).
5. Lift the pump heads off the housing (5).

i The magnetic valve of the drying system remains fitted in this situation.

Changing diaphragm

i Replace the diaphragms of two-headed pumps consecutively in order to ensure that the same number of diaphragm spacers is used as before.

1. Position the pump so that the diaphragm surface is upwards.
2. Turn the fan to bring one diaphragm (6) to top dead centre.
3. Using a small screwdriver, between the housing and the outer edge of the diaphragm, carefully lift the edge of the diaphragm lightly upwards at one point (making sure not to damage the housing). Now grip the edge of the diaphragm on opposite sides, unscrew it by turning anti-clockwise.
4. Take the diaphragm spacer(s) (7) off the connecting rod (8) and retain them.
5. Check that all parts are free from dirt and clean them if necessary.

6. Put the diaphragm spacer(s) (7) on the thread of the new diaphragm.
7. Fit the new diaphragm (6): hold the connecting rod (8) with one finger, and gently screw in (clockwise) the diaphragm with diaphragm spacers.
8. Turn the fan until the diaphragm is at the top dead centre. Using a small screwdriver, between the housing and the outer edge of the diaphragm, carefully lift the edge of the diaphragm lightly upwards at one point. Now grip the edge of the diaphragm on opposite sides (do not overstretch the diaphragm!) and tighten the diaphragm clock-wise.
9. Carry out steps 1 to 8 for the second pump head.

Changing valve plates/sealings

i Replacing the valve plates/sealings of pump heads consecutively.

1. Undo the two screws (3).
2. Separate the head plate (10) with top plate (2) from intermediate plate (9).
3. Remove the valve plates/sealings (1) from the intermediate plate.
4. Check that the valve seats, the head plate and intermediate plate are clean. If scratches, distortion, or corrosion are evident on these parts they should be replaced.
5. Lay the new valve plates/sealings (1) in the recesses in the intermediate plate. The valve plates/sealings for suction and pressure sides are identical, as are upper and lower sides of the valve plates/sealings.
6. Carry out steps 1 to 6 for the second pump head.
7. Dispose of the old diaphragms and valve plates/sealings properly.

Refitting pump head

1. Turn the fan to bring the diaphragm (6) of one pump head to medium position.
2. Place the intermediate plate (9), with valve plates/sealings (1), on the housing, in the position indicated by the marking (M).
3. Place the head plate (10) on the intermediate plate (9) in the position indicated by the marking (M).
4. Place top plate (2) in position and insert screws (3) with disk springs (4), and tighten them until the screw heads are just fully seated (do not completely tighten them!).

- i** The concave side of the first three disc springs must point away from the screw head, the next three towards it (see fig. 11, detail X).
5. Gently tighten the screws (**11**), evenly and diagonally.
 6. Turn the fan to check that the pump rotates freely.
 7. Now tighten screws (**11**) hand-tight.
 8. Tighten each of the screws (**3**) a half-turn more (tightening torque: 20 Ncm).
 9. Carry out steps 1 to 8 for the second pump head.
 10. Refit the pneumatic head connection: Place tube onto the connecting part of the angle fitting, turn angle fitting to a straight position and tighten the union nut.

Final steps

1. Refit the fan cover.
2. Reconnect suction and pressure line to the pump.
3. Reconnect the pump to the electricity supply.

If you have any questions about servicing call your KNF technical adviser (see last page for contact telephone number).

9. Troubleshooting



Extreme danger from electrical shock!

→ Disconnect the pump power supply before working on the pump.

DANGER

→ Make sure the pump is de-energized and secure.

→ Check the pump (see Tab. 13 to 16).

Pump does not transfer	
Cause	Fault remedy
No voltage in the power source	→ Check room fuse and switch on if necessary.
Thermal switch has operated following to over-heating.	→ Disconnect pump from mains. → Allow pump to cool. → Trace cause of over-heating and eliminate it.
Connections or lines blocked.	→ Check connections and lines. → Remove blockage.
External valve is closed or filter is clogged.	→ Check external valves and filters.
Condensate has collected in pump head.	→ Switch the drying system on or reduce t_3 respectively (see chapter 7.4 with regard to changing the value which has been set)
Diaphragm or valve plates/sealings are worn.	→ Replace diaphragm and valve plates/sealings (see chapter 8.3).

Tab. 13

Flow rate, pressure or vacuum too low	
The pump does not achieve the output specified in the Technical data or the data sheet.	
Cause	Fault remedy
Condensate has collected in pump head.	→ Switch the drying system on or reduce t_3 respectively (see chapter 7.4 with regard to changing the value which has been set)
There is gauge pressure on pressure side and at the same time vacuum or a pressure above atmospheric pressure on suction side.	→ Change the pressure conditions.
Pneumatic lines or connection parts have an insufficient cross section.	→ Disconnect pump from system to determine output values. → Eliminate throttling (e.g. valve) if necessary. → Use lines or connection parts with larger cross section if necessary.
Leaks occur on connections, lines or pump head.	→ Check that tubes sit correctly on hose nozzles. → Replace leaky tubes. → Eliminate leaks.
Connections or lines completely or partially clogged.	→ Check connections and lines. → Remove the clogging parts and particles.
Head parts are soiled.	→ Clean head components.
Diaphragm or valve plates/sealings are worn.	→ Replace diaphragm and valve plates/sealings (see chapter 8.3).

Flow rate, pressure or vacuum too low	
The pump does not achieve the output specified in the Technical data or the data sheet.	
Cause	Fault remedy
Replaced diaphragms and valve plates/sealings	<ul style="list-style-type: none"> ➔ Check that the spacers have been replaced onto the diaphragm screw thread. ➔ Check head connection and hose connections for leaks. ➔ Possibly carefully tighten the outer screws (fig. 10/4 or 11/11) of the top plate crosswise.

Tab. 14

Pump is switched on, but does not run, the on/off-switch on the pump is not lit	
Cause	Fault remedy
Pump is not connected with the power source.	➔ Connect pump to mains power.
No voltage in the power source	➔ Check room fuse and switch on if necessary.
Fuse in the pump is defective.	<ul style="list-style-type: none"> ➔ Remove pump's mains plug from the socket. ➔ All pumps except for N 860.3 FT.40.18: Loosen marked lid on underside of the pump. ➔ Pump N 860.3 FT.40.18: Open connecting box of the pump (see fig. 3/7). ➔ Select and replace suitable fuse (see chapter 4).

Tab. 15

Pump is switched on, but does not run, the on/off-switch on the pump is lit	
Cause	Cause
The thermal switch has opened due to overheating	<ul style="list-style-type: none"> ➔ Remove pump's mains plug from the socket. ➔ Allow pump to cool. ➔ Trace cause of over-heating and eliminate it.

Tab. 16

Fault cannot be rectified

If you are unable to determine any of the specified causes, send the pump to KNF Customer Service (see last page for the address).

1. Flush the pump to free the pump head of dangerous or aggressive gases (see chapter 8.2.1).
2. Clean the pump (see chapter 8.2.2).
3. Send the pump, together with completed Health and Safety Clearance and Decontamination Form (Chapter 12), to KNF stating the nature of the transferred medium.

10. Spare parts

10.1. Service Sets

A Service Set contains all replacement parts needed for one complete service:

- 2 diaphragms
- 4 valve plates/sealings

Service set for pump	Order-No.
N 820.3 FT.40.18	057358
N 840.3 FT.40.18	057359
N 842.3 FT.40.18	057359
N 860.3 FT.40.18	047499

Tab. 17

10.2. Head plates and intermediate plates (white)

Pump type	Order-No. head plate		Order-No. intermediate plate	
	Head 1	Head 2	Head 1	Head 2
N 820.3 FT.18	025848	027108	057278	057278
N 840.3 FT.18	025883	027195	057176	057176
N 842.3 FT.18	042370	042369	058088	058088
N 860.3.FT.18	045981	045982	049601	046132

Tab. 18

10.3. Head plates and intermediate plates (black)

Pump type	Order-No. head plate		Order-No. intermediate plate
	Head 1	Head 2	
N 820.3 FT.18	304249	304252	304246 (2x)
N 840.3 FT.18	304250	304253	304247 (2x)

Tab. 19

11. Returns

Pumps and systems used in laboratories and process-based industries are exposed to a wide variety of conditions. This means that the components contacting pumped media could become contaminated by toxic, radioactive, or otherwise hazardous substances.

For this reason, customers who send any pumps or systems back to KNF must submit a Health and safety clearance and decontamination form in order to avoid a hazardous situation for KNF employees. This Health and safety clearance and decontamination form provides the following information, among other things:

- physiological safety
- whether medium-contacting parts have been cleaned
- whether the equipment has been decontaminated
- media that have been pumped or used

To ensure worker safety, work may not be started on pumps or systems without a signed Health and safety clearance and decontamination form.

For optimal processing of a return, a copy of this declaration should be sent in advance via e-mail, regular mail, or fax to KNF Customer Service (refer to final page for address). In order to avoid endangering employees who open the shipment's packaging, despite any residual hazards, the original version of the Health and safety clearance and decontamination form must accompany the delivery receipt on the outside of the packing.

The template for the Health and safety clearance and decontamination form is included with these Operating Instructions and may also be downloaded from the KNF website.

The customer must specify the device type(s) and serial number(s) in the Health and safety clearance and decontamination form in order to provide for the unambiguous assignment of the Declaration to the device that is sent to KNF.

In addition to the customer's declaration of physiological safety, information about operating conditions and the customer's application are also of importance to ensure that the return shipment is handled appropriately. Therefore, the Health and safety clearance and decontamination form requests this information as well.

12. Health and safety clearance and decontamination form



Form: Rev. 02 / download: www.knf.com

Health and safety clearance and decontamination form

This declaration must be present and complete (the original must accompany the shipment's delivery receipt) before the returned device can be examined.

Device type:

Serial number(s):

.....

.....

Reason for returning the device (please describe in detail):

(The device(s) was(were) in operation yes no)

.....

.....

.....

.....

.....

We confirm that the above device(s)

has(have) pumped exclusively **physiologically unobjectionable** media and that it(they) are free of hazardous materials and any materials that are harmful to health.

Pumped media:

The device(s) was(were) cleaned yes no

has(have) pumped media of the following category(categories) which are not physiologically unobjectionable and that cleaning of the device(s) (potentially only media-contacting parts) is required.

Name, chemical formula, Material Safety Data Sheet

aggressive

biological

radioactive

toxic

other

The device(s) was(were) decontaminated and work can proceed without special measures yes

Method / proof:

.....

The device(s) was(were) not decontaminated and special measures are required before starting work yes

Measures:

.....

Legally binding declaration

We herewith affirm that the information provided in this form is correct and complete. Shipment of the devices and components is in compliance with statutory regulations.

.....
 Company (stamp) Date Name Authorized signature Position

KNF worldwide

Please find our local KNF partners at: www.knf.com