

Deep Ledge Utility Cart
Chariot de service à rebord
Carro utilitario con barandas

ASSEMBLY INSTRUCTIONS
INSTRUCTIONS D'ASSEMBLAGE
INSTRUCCIONES DE ENSAMBLAJE

Properly assembled cart will have no grooves exposed above top shelf.

Si le chariot est proprement monté, il n'y aura aucune rainure visible sur l'étagère supérieure.

En un carro ensamblado de modo correcto, no habrá ranuras expuestas sobre la repisa de arriba.



This Shelf at Top

Étagère Supérieure

Esta Repisa Arriba

Shelves must be assembled before casters and inserts.

Etagères doivent être montées avant roulettes et autres attributs.

Ensamble las repisas antes de colocar las ruedas y los acopladores.



InterMetro Industries Corporation
North Washington Street, Wilkes-Barre, PA 18705
For Product Information Call: 1-800-433-2232
Visit Our Web Site: www.metro.com

Deep Ledge Utility Cart
Chariot de service à rebord
Carro utilitario con barandas

LIST OF COMPONENTS

LISTE DES COMPOSANTS

LISTA DE COMPONENTES

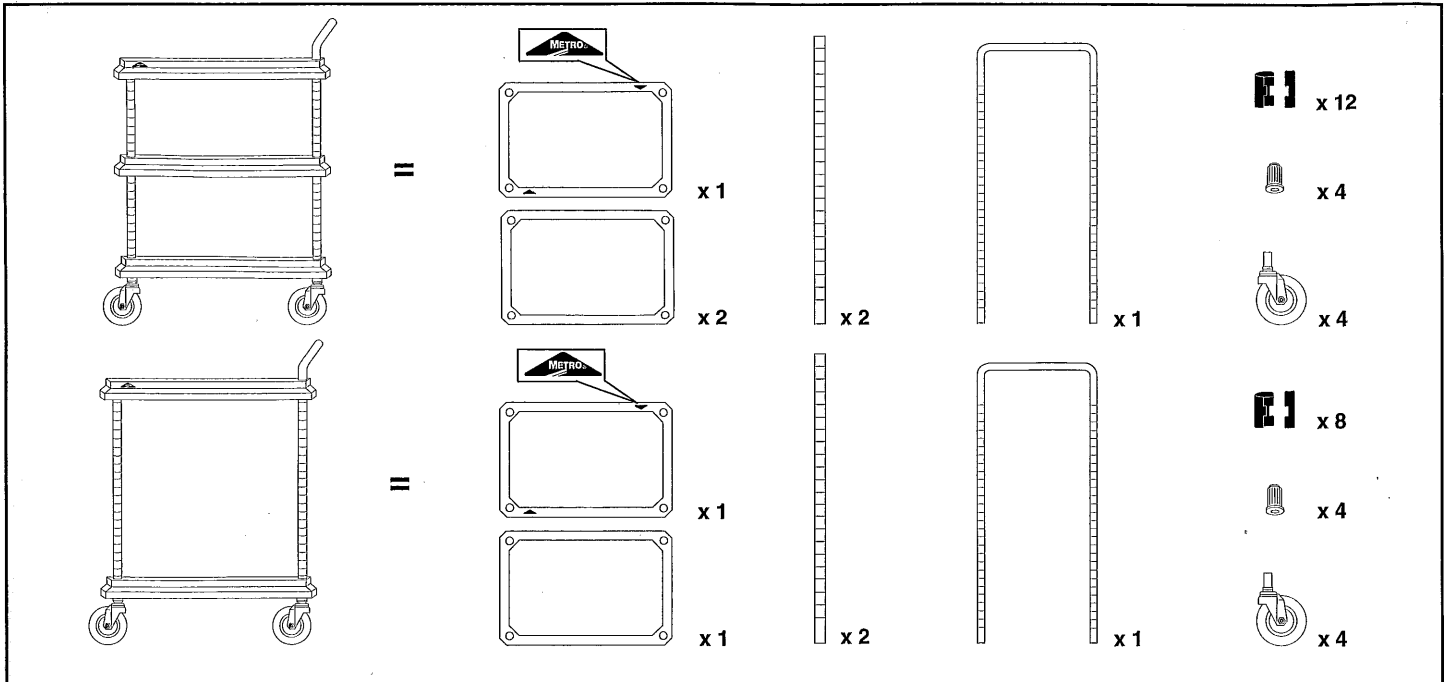

ATTENTION!	Shelves must be assembled before casters and inserts.
ATTENTION!	Etagères doivent être montées avant roulettes et autres attributs.
ATENCIÓN!	Ensamble las repisas antes de colocar las ruedas y los acopladores.

1

A

Raise shelf as high as possible to install split sleeves.
 Pour installer les gaines de division, soulevez l'étagère le plus haut possible.
 Para instalar los manguitos de división, levantar la repisa lo más alto posible.

B

Install split sleeves six grooves up from Site Select™ double groove.
 Installez les gaines de division à un écart de six rainures au-dessus de la double rainure Site Select™
 Instalar los manguitos de división a seis ranuras de distancia de la doble ranura Site Select™

NOTE: Properly assembled cart will have NO grooves exposed above top shelf.
NOTE: Si le chariot est proprement monté, il n'y aura aucune rainure visible sur l'étagère supérieure.
NOTE: En un carro ensamblado de modo correcto, no habrá ranuras expuestas sobre la repisa de arriba.

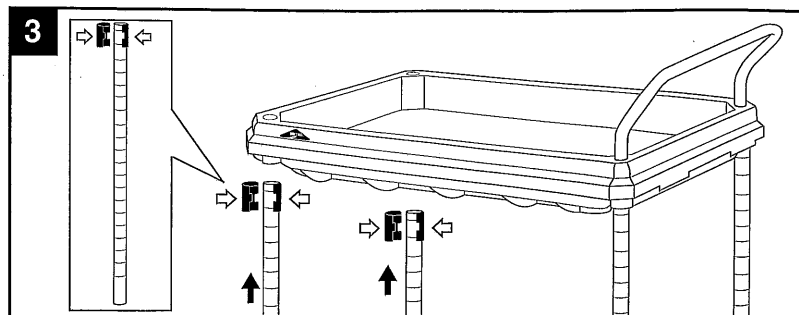
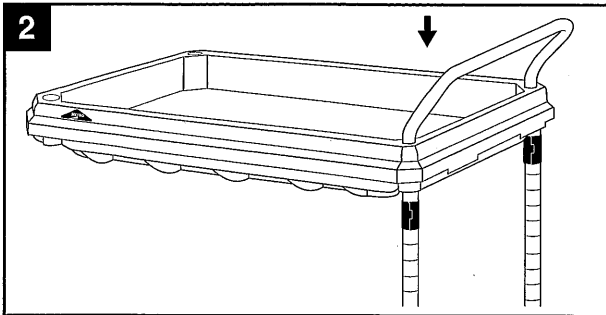

For 3-shelf unit, install middle shelf now. 4
Pour chariot à 3 niveaux, monter l'étagère intermédiaire maintenant. 4
Para un carro con tres repisas, instale la repisa central ahora. 4

For 2-shelf unit, proceed to step 6.
Pour chariot à 2 niveaux, aller 6.
Para un carro con dos repisas, vaya al numero 6.

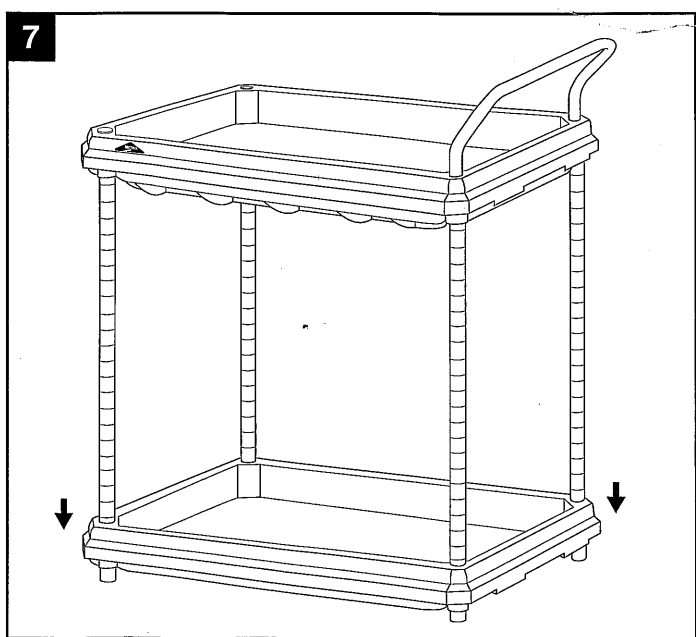
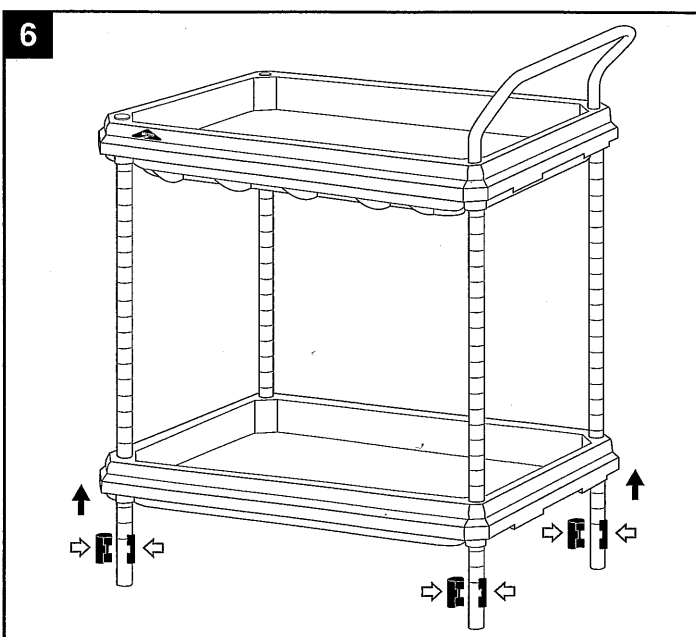
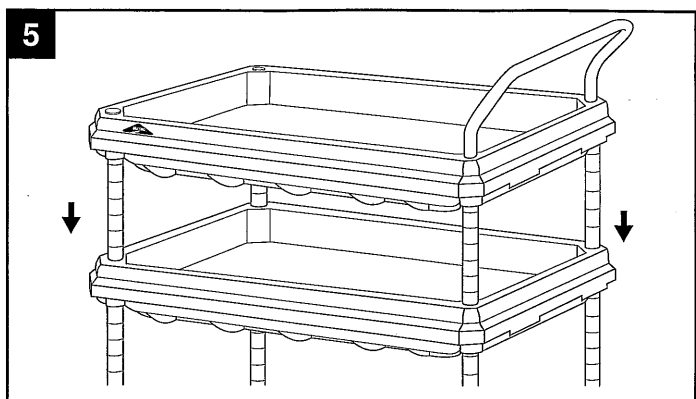
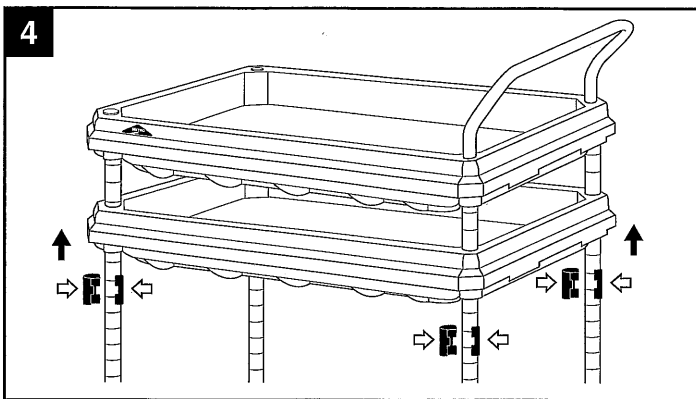

Deep Ledge Utility Cart
Chariot de service à rebord
Carro utilitario con barandas

8

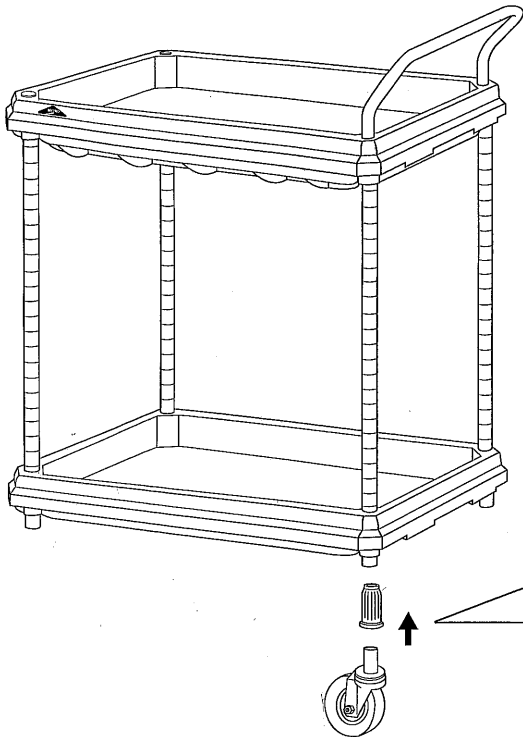

ATTENTION! Shelves must be assembled before casters and inserts.

ATTENTION! Étagères doivent être montées avant roulettes et autres attributs.

ATENCION! Ensamble las repisas antes de colocar las ruedas y los acopladores.

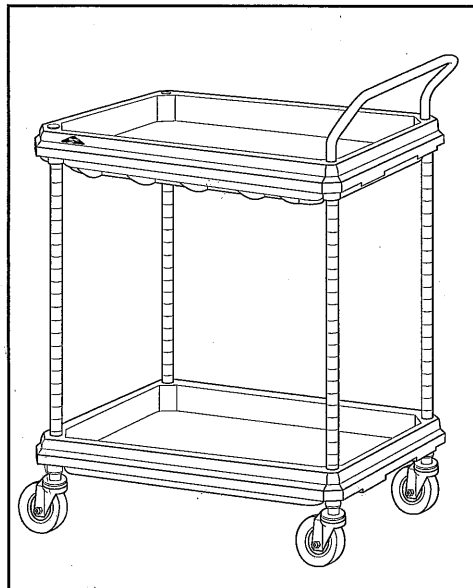
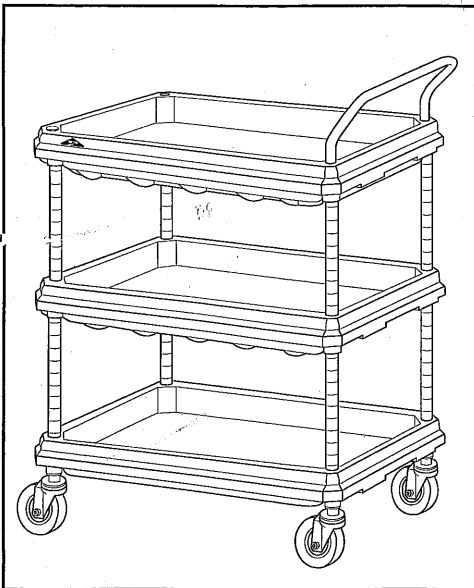
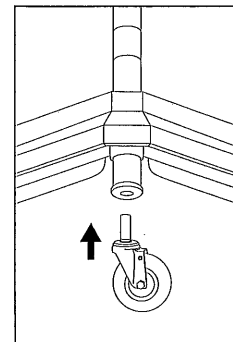
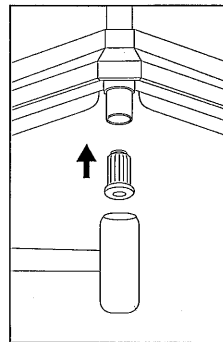

WEIGHT LOAD CAPACITY

Shelf 150 lbs. (68 kg)
 Unit 400 lbs. (182 kg)

CHARGE MAXIMALE

Étagère 150 lbs. (68 kg)
 Unité 400 lbs. (182 kg)

CAPACIDAD DE CARGA EN PESO

Repisa 150 lbs. (68 kg)
 Unidad 400 lbs. (182 kg)



InterMetro Industries Corporation
 North Washington Street, Wilkes-Barre, PA 18705
 For Product Information Call: 1-800-433-2232
 Visit Our Web Site: www.metro.com

L01-352
 Rev. A
 12/00

Information and specifications are subject to change without notice. Please confirm at time of order.